



# **Strain Gauge Project**

## **Final Proposal Report**

**Yifan Chen**  
**Zhicheng Jiang**  
**Tianpai Le**  
**Ziyu Wei**  
**Rui Xu**

**Summer 2021**



**Project Sponsor:** Department of Mechanical Engineering, NAU

**Faculty Advisor, Sponsor Mentor & Instructor:** Dr. David Trevas



## **DISCLAIMER**

This report was prepared by students as part of a university course requirement. While considerable effort has been put into the project, it is not the work of licensed engineers and has not undergone the extensive verification that is common in the profession. The information, data, conclusions, and content of this report should not be relied on or utilized without thorough, independent testing and verification. University faculty members may have been associated with this project as advisors, sponsors, or course instructors, but as such they are not responsible for the accuracy of results or conclusions.



## EXECUTIVE SUMMARY

This is the report of the Strain Gauge Team's project. The goal of this project is to build a laboratory strain measurement device that can simultaneously measure axial load, bending, torsion and internal pressure. The rest of the report will give a description of the team's progress in generating their design.

The client of this project is Dr. David Trevas, who is also the course instructor and project sponsor. Beginning with identifying the project and interviewing the client, the team constructed a House of Quality table to determine the customer needs and engineering requirements. With the assistance from Dr. Trevas, the team confirmed that the approach to achieve the project's purpose would be using strain gauges and Arduino. In the next few weeks, each member of the team read through academic journals, books and other sources, before carrying out detailed calculations to analyze the technical aspects of the project. Those calculations not only helped the team to verify the feasibility of the device, but also provided solid support to the team's concept generation process. At the end of this semester, in order to test the reliability of the concept, the team built a prototype. The prototype passed the test successfully. As a supplemental evaluation of the project, the team also conducted an FMEA analysis on the overall design. By studying the possible failure modes and their causes, the team came up with a lot of constructive ideas to minimize, or even prevent the occurrences of those failure modes, and how an individual action will affect another in the problem-solving process.

After completing the above steps, a design concept was generated by the team. In general, the whole device can be divided into two sections, one being electronics and the other being load cells. The electronics section for an individual measurement device is composed of an Arduino board, a touchscreen, an HX711 load cell amplifier, and a Wheatstone bridge circuit. The overall structure of this section is sequential. The Wheatstone bridge circuit, HX711, and the Arduino board, are connected one by one. The three also make up the physical core of this section. In addition, the Arduino board is externally connected to the computer via USB port, with programs written within the Arduino application to control the running of the device. The touchscreen is connected to the Arduino board as well.

The second section, the load cell, is basically the unit combined by strain gauges and a metal piece. According to the load type, three types of metal designs with different shapes and dimensions will be used. The configuration of four load cells is like a puzzle, which makes the device detachable and more portable. Through the Wheatstone bridge circuit, the load cell would achieve communication with the electronics.

Apart from the core components, there are some accessories to supplement the functionality of the device, which includes mechanical clamping fixture, a bottom plate (both applied to the entire device), pulleys (applied to axial strain measurement device, translates the gravity of the load to a horizontal force), levers (applied to torsional strain measurement device, used for generating torsion), and air valves (applied to internal pressure strain measurement device, used for generating pressure). Although not all of the above components have been turned into reality at this stage, a majority of them has been incorporated into the prototype which to some extent proved the device's ability to make successful runs.

Through the efforts of the group members and the guidance of Dr. Trevas, the performance of the team's current design has lived up to the expectations. With the progress being made, the team will finalize this project with the construction of an actual product next semester.



# TABLE OF CONTENTS

## Contents

<b>DISCLAIMER</b>	1
<b>EXECUTIVE SUMMARY</b>	2
<b>TABLE OF CONTENTS</b>	3
<b>1 BACKGROUND</b>	1
1.1 Introduction	1
1.2 Project Description	1
<b>2 REQUIREMENTS</b>	2
2.1 Customer Requirements (CRs)	2
2.2 Engineering Requirements (ERs)	2
2.3 Functional Decomposition	2
2.3.1 Black Box Model	2
2.3.2 Functional Model/Work-Process Diagram/Hierarchical Task Analysis	3
2.4 House of Quality (HoQ)	4
2.5 Standards, Codes, and Regulations	5
<b>3 Testing Procedures (TPs)</b>	6
3.1 Testing Procedure 1: Maximum Running Cycles, Load Range	7
3.1.1 Testing Procedure 1: Objective	7
3.1.2 Testing Procedure 1: Resources Required	7
3.1.3 Testing Procedure 1: Schedule	7
3.2 Testing Procedure 2: Accuracy and sensitivity	7
3.2.1 Testing Procedure 2: Objective	7
3.2.2 Testing Procedure 2: Resources Required	8
3.2.3 Testing Procedure 2: Schedule	8
3.3 Testing Procedure 3: Size and Device weight	8
3.3.1 Testing Procedure 3: Objective	8
3.3.2 Testing Procedure 3: Resources Required	8
3.3.3 Testing Procedure 3: Schedule	8
3.4 Testing Procedure 4: Cost	9
3.4.1 Testing Procedure 4: Objective	9
3.4.2 Testing Procedure 4: Resources Required	9
3.4.3 Testing Procedure 4: Schedule	9
<b>4 Risk Analysis and FMEA</b>	10
4.1 Critical Failures	12





4.2 Risks and Trade-offs Analysis	12
<b>5 Design Selected - First Semester</b>	12
5.1 Design Description	12
5.2 Rationale for Design Selection	13
5.2.1 Axial Load	13
5.2.2 Bending	13
5.2.3 Torsion	14
5.2.4 Internal Pressure	14
5.3 Implementation Plan	15
5.3.1 Fabricate prototype and proof-of-concept creation	15
5.3.1.1 Overview	15
5.3.1.2 Limitations	17
5.3.1.3 Prototype Decomposition & Testing Procedure	17
5.3.1.4 Result & Conclusion	19
5.3.2 Bill of materials	20
5.4 Subsystem Concepts with CAD models	20
5.4.1 Subsystem #1: Load Cell	20
5.4.2 Subsystem #2: Data Acquisition	20
5.4.3 Subsystem #3: Data Processing	21
5.4.4 Subsystem #4: Serial Communication	22
5.4.5 Subsystem #5: Assembly	22
5.5 Gantt chart	22
<b>6 Conclusion</b>	23
<b>7 REFERENCES</b>	24
<b>8 APPENDICES</b>	25
8.1 APPENDIX A: A rduino Codes	25
8.2 APPENDIX B: Processing Codes	28
8.3 Appendix C: Bill of materials	31
8.4 Appendix D: Gantt chart	34



# 1 BACKGROUND

## 1.1 Introduction

The goal of this project is to build a laboratory strain measurement device. The device is supposed to be multifunctional, which could measure strain under four different load types: axial load, bending, torsion and internal pressure. On top of that, it needs to be accurate and user-friendly enough to reach its educational purposes.

The client and main stakeholder of this project is Dr. David Trevas from the Department of Mechanical Engineering (ME). Having long been teaching the courses of Mechanical Design, Dr. Trevas is not so satisfied with some basic concepts that ME students have upon entering his course, especially with the concept of strain. Currently, the prerequisite course that introduces strain is taught by the Department of Civil and Environmental Engineering (CENE), which Dr. Trevas feels cannot quite meet the needs of ME students. Therefore, Dr. Trevas is keen on developing such a device designed for ME students, which leads to the birth of this project. The project is also sponsored by the Department of Mechanical Engineering.

The device developed in this project will be directly beneficial to ME students, as they will learn the strain measurement process in a way more relevant to their major and make smoother transitions to upper level courses. Also, it will provide great assistance to Dr. Trevas and his colleagues' teaching. Eventually, with new design ideas and budget control added to the device, it is likely to be promoted to elementary and middle schools to boost basic education.

## 1.2 Project Description

Following is the original project description provided by the sponsor:

“Strain gages are the most important measurement device in mechanical engineering. They are at the heart of digital scales, load cells and pressure transducers. Measurements of force, weight, torque, pressure, stress and strain are routinely made with these tiny inexpensive sensors. While delicate on their own, strain gages are rugged and reliable once they are properly installed. While single gages are useful in some applications, configurations like tees and rosettes can be better in other one. Strain gages are electrical resistors whose resistance varies under strain, and by arranging them in quarter-bridge, half-bridge or full-bridge circuits, we can extract the state of stress observed. This project will build your knowledge and mastery of Strength of Materials (Hooke's Law in 3 dimensions), Circuits (Bridges) and Programming (Data Acquisition using Arduino and the HX711 bridge chip).

The system will also have a data acquisition system and a user's manual that will describe experiments that can be performed with the apparatus.”



## 2 REQUIREMENTS

**Introduction:** In this chapter, the team will have a detailed discussion of the project requirements prior to generating design concepts. Starting with the House of Quality table, the team will establish relationships between customer needs and customer requirements. After that, there will be a Black Box Model and a Functional Model respectively to decompose the device according to their functionalities.

### 2.1 Customer Requirements (CRs)

1. Reliable for experimental use: Measurement error as little as possible.
2. Affordable: The price of the equipment is suitable for most clients and under the budget.
3. Easy to use: Anyone without professional training can quickly become familiar with the use of the device through the product manual.
4. Suitable for different occasions: Can measure four different stresses.
5. Portable: This is laboratory equipment. Need to be easy to bring in and out.
6. Safety: Make sure that no one will be hurt during the operation.
7. Could measure strain accurately: Accuracy is the most important element of the device, and has the highest priority.

### 2.2 Engineering Requirements (ERs)

1. Maximum Running Cycles: Maximum number of repetitive measurements, under the premise of ensuring accuracy and after doing a lot of research. The team stipulates that it can reach 100,000 times, the tolerance is  $\pm 10,000$ . We hope that the equipment is durable enough
2. Accuracy: The margin of error is 0.5. Satisfying this condition can prove the high precision of the equipment.
3. Load Range: The force that can be measured is in the range of -500N to 500N. The tolerance is  $\pm 50$ N. This is based on the project requirement.
4. Sensitivity: The minimum value of the strain gauge that can be sensed is 1 microstrain.
5. Size: The target size is 2000mm\*2000mm\*500mm. The size tolerance should be less than 10%.
6. Device Weight: The max weight of the device is 22.5 kg, the tolerance should be  $\pm 2.5$  kg.
7. Cost: The total budget of the device needs to be less than \$1500, and the team hopes to control the cost around \$1200, the tolerance is  $\pm$  \$300.
8. Material Choice: The selected material is Aluminum. This is the most suitable material based on the durability, processability, cost, and quality of the material.

### 2.3 Functional Decomposition

#### 2.3.1 Black Box Model

**Introduction:** The Black Box Model below (Figure 1) shows that the function of the device is to measure the strain under different load types.

For the material flow, the device is actuated by human adding external load to the load cell. A temporary deformation of the load cell marks the end of a single measurement.

With the actuation of the device, mechanical energy is also put into the system (pneumatic energy for internal pressure strain). Combined with the energy provided by the power supply, they will ultimately turn into the electric potential acting on the Wheatstone bridge circuit, with a small portion becoming internal energy that would be released into the atmosphere.

The electric potential above generates analog signals, which is followed by analog-to-digital conversions. The process is mainly accomplished by HX711 in the electronics section. Also, with a touch screen



displaying the results, visual signals are included from the output.



Figure 1: Black Box Model

**Discussion:** The Black Box Model gives the team a brief idea of the key features of the device and how it functions. On top of this model, the team put everything in detail and therefore generated a hypothesized functional model in the following section.

### 2.3.2 Functional Model/Work-Process Diagram/Hierarchical Task Analysis

**Introduction:** Overall, the functional model of the device (Figure 2) is divided into three sections in an order of material, energy, and signal. At the same time, the model goes through a complete working process of the device and splits the device into different subsystems.

At the top of this model is the material section. It also corresponds with the physical/mechanical parts of the device. The key feature in this section is the load cell (including strain gauges). When the external load/pressure (expressed by “hand”) is exerted on the load cell, the load cell deforms. Changes in energy caused by the deformation would lead to the next section of the model.

Next is the energy section. There are two energy sources in this device. One is the mechanical energy generated by “hand”, and the other is the electrical energy provided by the power supply on Arduino. The two types of energy would converge into the strain gauge, causing a resistance change. The change itself would alter the electrical energy on the strain gauge, before passing onto the Wheatstone bridge. Meanwhile, a small portion of energy would become internal energy and dissipate into the atmosphere.

The signal flow of the device starts to gain its importance on the Wheatstone bridge. Along with the approach of the energy, the voltage difference could also be recognized as analog signal. With clock signals generated by the following HX711, this part of the signal would turn into digital form, before being read by the Arduino environment. Eventually, a screen will put all the results into display as visual signals.

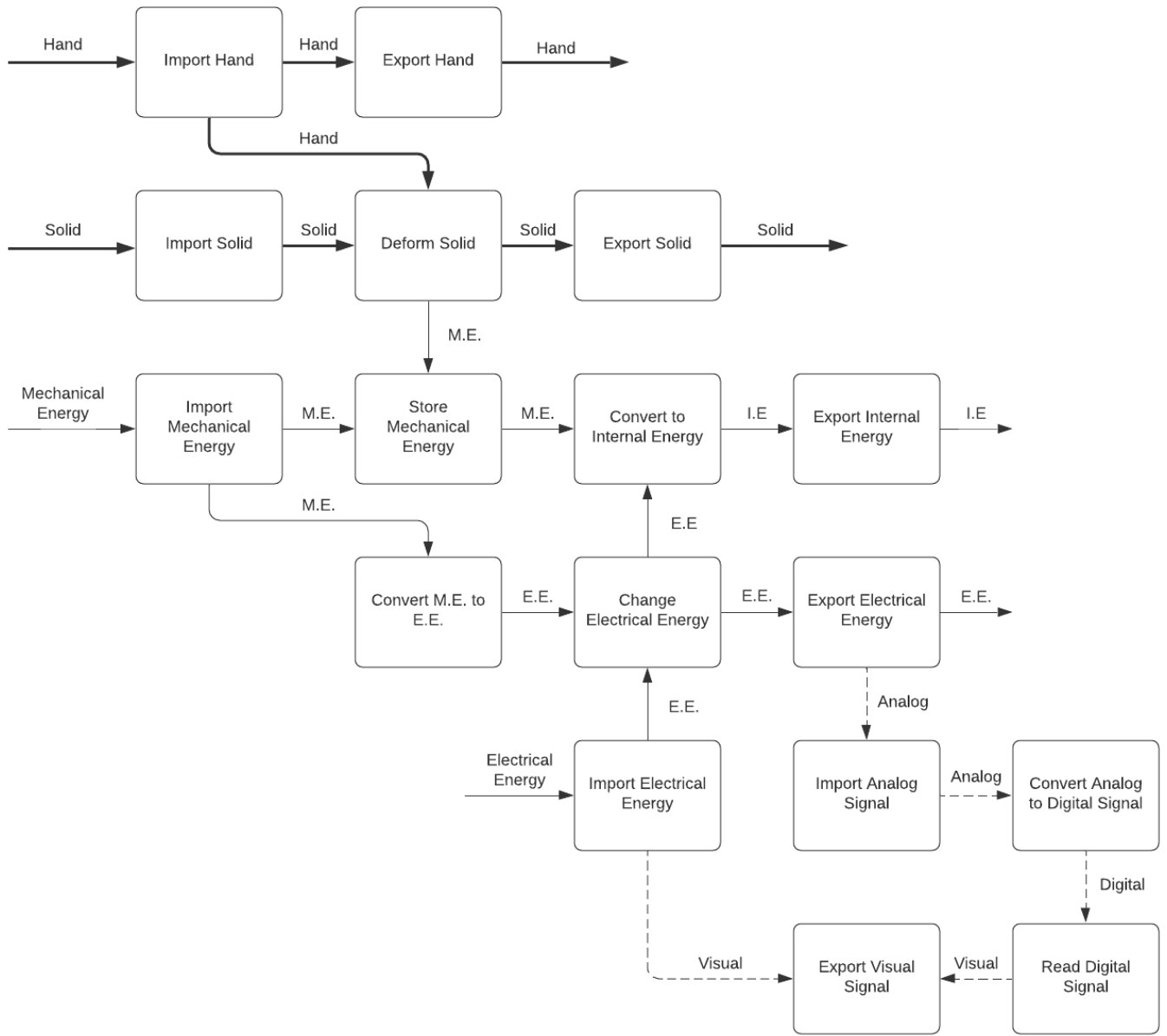

Figure 2: Functional Model

**Discussion:** The functional model effectively divides the device into five subsystems according to their functionalities: load cell, data acquisition (Wheatstone bridge), data processing (HX711 and Arduino board), serial communication (Arduino program and screen), and assembly (casing). Based on the division on subsystems, the team came up with multiple design concepts in Section 4.



## 2.4 House of Quality (HoQ)

Table 1: House of Quality

House of Quality (HoQ)										
Customer Need	Weight	Engineering Requirement	Maximum Running Cycles	Accuracy	Load Range	Sensitivity	Size	Device Weight	Cost	Material Choice
1. Reliable for experimental use	4		3	9	3	3				9
2. Affordable	2		1	3	1	3		3	1	9
3. Easy to use	3				3	1		1	1	1
4. Suitable for different occasions	3			1	1	1				
5. Portable	1							9	9	
6. Safety	3		1					3	1	1
7. Could measure strain accurately	5		1	9	3	9				3
<b>Absolute Technical Importance (ATI)</b>			22	90	41	69		27	17	48
<b>Relative Technical Importance (RTI)</b>			7	1	5	2		6	8	3
<b>Target ER Values</b>			10 <sup>5</sup>	0.5	500	1	2000*2000*500	10	1200	Aluminum
<b>Target ER Units</b>			cycles	Error%	N	microstrain	mm <sup>3</sup>	kg	\$	
<b>Tolerances of ERs</b>			±10 <sup>4</sup>	±0.1	±50			±2	±300	
<b>Testing Procedure (TP#)</b>			Fatigue							

Our team set 7 customer requirements and 9 ERs, through our research and conclusion by ourselves. CRs mainly include the measurement must be reliable and accurate; it should be easy to use and carry; and the device should be inexpensive and should be safe enough. Among them, accurate measurement is the most important CR, followed by the reliability and safety of the device, and finally, if it is cheap and easy to carry, it will be great.

Our team created the QFD chart to map customer requirements to engineering requirements by evaluating and scoring. You can see the details of the scoring in this slide. And after the calculation, accuracy gets the highest ATI Points which means it is the most important ER. We hope the accuracy of the equipment can reach an error of less than 0.5%. The second is sensitivity, we hope it should be within 1 microstrain. The ATI scores obtained by the cost and material choice are almost the same. Our team hopes that the cost can be controlled around US\$1,200; the best choice of material is aluminum. Overall, what we get from the QFD chart meets our expectations.



## 2.5 Standards, Codes, and Regulations

Table 2: Standards of Practice as Applied to this Project

<b><u>Standard Number or Code</u></b>	<b><u>Title of Standard</u></b>	<b><u>How it applies to Project</u></b>
ANSI H35.2	Standard of American National Dimensional Tolerances for Aluminum Mill Products	A reference to the standard of dimensional tolerances for aluminum products, providing the accuracy of machining.
ASTM B557-15	Standard Test Methods for Tension Testing Wrought and Cast Aluminum- and Magnesium-Alloy Products	A reference to the strength data and standard deviations of Aluminum 2024 under axial load, will be used for strain calculations.
ASTM B881-17	Standard Terminology Relating to Aluminum- and Magnesium-Alloy Products	Helps with appropriate naming of the metal used for the load cell based on its dimensions.
ASTM B211/B211M-19	Standard Specification for Aluminum and Aluminum-Alloy Rolled or Cold Finished Bar, Rod, and Wire	A reference to the properties of different Aluminum alloys, influencing the material choice (Aluminum 2024) for the load cell.



### 3 Testing Procedures (TPs)

In this section, our team sets test methods for each engineering requirement to make the team's final design meet. This includes maximum running cycles, accuracy load range sensitivity, size device weight, cost material choice. Only by meeting these requirements can we perform better in future physical operations and meet customer needs to the greatest extent

#### 3.1 Testing Procedure 1: Maximum Running Cycles, Load Range

The process of these tests is to determine the maximum running cycles and load range of the metal. It proves the engineering requirements of Maximum Running Cycles and load range. These tests will be finished in the final semester.

##### 3.1.1 Testing Procedure 1: Objective

**Introduction:** By repeatedly repeating the maximum load that may be used in the experiment, the metal fatigue is measured at intervals and drawn into a curve to determine its maximum running cycles. Judge its Load Range by applying load until the metal undergoes irreversible deformation and fracture.

##### 3.1.2 Testing Procedure 1: Resources Required

Metal material being tested \*2

Device for measuring metal fatigue \*1

##### 3.1.3 Testing Procedure 1: Schedule

These tests will be conducted in October of the next semester, and the three projects will be tested together.

#### 3.2 Testing Procedure 2: Accuracy and sensitivity

**Introduction:** The second test features the engineering requirements of accuracy and sensitivity. Due to the fact that both requirements are linked not only to the strain gauges but to the computer, it makes a lot of sense to put them into a combined test. Regardless of what requirement is tested, the core is to get strain readings from the computer. The test is also a direct reflection of the effectiveness of the device, making it the most important among all tests.

##### 3.2.1 Testing Procedure 2: Objective

Both accuracy and sensitivity tests involve strain under all four load types. For the accuracy test, the measured strain will be compared with the values obtained from other sources. Depending on the difficulty of getting them, the reference values can be experimental or theoretical. For example, the strain under compression can be directly related to weight, which allows using the digital scale as a reference measurement device. However, for some types of strain, it is more convenient to test the accuracy using pure mathematics. Based on the results of the accuracy test, it is expected that the program will be slightly modified for calibration.

The sensitivity test will give the team an idea of how strain changes on the device under certain force gradients. The limiting factors of the device sensitivity include the load cell and HX711. However, since HX711 is capable of generating 24-bit digital signals, it is sensitive enough to split hundreds or thousands





of microstrain. Therefore, the size of the load cell is the real matter -- Of course, a smaller load cell would be more sensitive, but it is also not so good to see a huge strain leap under a slight increase in external force. In consequence, the aim of the test is not maximizing but controlling the sensitivity of the device.

### **3.2.2 Testing Procedure 2: Resources Required**

People: All members of the group

Software: Arduino program and its extensions (e.g. program on Processing)

Hardware: A complete set of device (including Arduino board, HX711, load cell) and weights

Location: Library

### **3.2.3 Testing Procedure 2: Schedule**

Part of the test has been accomplished this semester, which mainly checks if the Arduino could run normally and get reasonable readings from strain gauges. The outcomes were positive.

The rest of the test is expected to take a week next semester. The test of both requirements will include pre-calculations, especially for the sensitivity test which needs to figure out the proper size of the load cell and positioning of strain gauges. Although the test won't need a complete prototype, all functional components must be connected and cooperate well with Arduino. Therefore, the estimated time for the test will be early October.

## **3.3 Testing Procedure 3: Size and Device weight**

### **3.3.1 Testing Procedure 3: Objective**

First, the length, width, and height of the equipment are measured with a length measuring tool. The ER standard set by the team is 2m\*2m\*0.5m. Then measure the weight of this equipment with a weight measuring instrument. The weight range set by the team is 20-25kg calculated by Solidworks. According to CRs, the equipment should be suitable for laboratory use. Therefore, it is necessary to ensure that the equipment has the appropriate size and weight.

### **3.3.2 Testing Procedure 3: Resources Required**

Person: Two or more members of the team

Software: Solidworks, Excel

Hardware: Laptop, Electronic scale, Ruler or tape measure

Location: Engineering building

### **3.3.3 Testing Procedure 3: Schedule**

Both the size and weight of the device can be previewed/predicted on the CAD model through Solidworks, making the test easier to pass under adjustments in advance. The actual test will be carried out around mid-October, right after a prototype of the device is built. Also it won't take long to complete, and the estimated time is 30 minutes.



### **3.4 Testing Procedure 4: Cost**

#### **3.4.1 Testing Procedure 4: Objective**

For the cost test, our team uses the BOM table for calculation and analysis. The overall calculation of the cost plan designed by the team is carried out through the automatic summation of Excel. Our team can replace and reduce some parts that are too costly.

#### **3.4.2 Testing Procedure 4: Resources Required**

Person: Budget Liaison

Software: Excel of the BOM form

Hardware: Laptop

Location: Engineering building

#### **3.4.3 Testing Procedure 4: Schedule**

Our testing of equipment cost runs through the entire equipment installation. The time is set in the middle of the semester. Before running the test, we need to carry out model design and installation step analysis of the entire device in advance. This can help our team complete the final improvement of the BOM. So as to calculate and test the cost.



## 4 Risk Analysis and FMEA

In this part, this team mainly focused on the risk analysis and finished a complete FMEA. During the table, this team listed ten potential sub-risks, and analyzed their causes and possible problems. The team ranked the risk by the RPN point. The RPN is equal to  $S \times O \times D$ . Higher RPN numbers signify more risks. Moreover, for each risk, the team proposed test methods and solutions.

Table 3: FMEA Part 1

	<b>Part # and Functions</b>	<b>Potential Failure Mode</b>	<b>Potential Effect(s) of Failure</b>
1	Electronics part	Circuit Failure	The entire device cannot function
1.5	Strain Gages—Linear Pattern	General Failure	The entire device cannot function
3.1	Metal shim	Yielding	Deformation no longer elastic, cause error readings
3.2	Metal bar	Yielding	Deformation no longer elastic, cause error readings
3.2	Metal hollow bar	Yielding	Deformation no longer elastic, cause error readings
3.3	Metal hollow bar	Surface Fatigue	Air leakage, unable to produce deformation
3.1-3.3	Metal shim/bar/hollow bar	Fatigue Failure	Cracks from the interior, ultimately cause fracture
3.4	Mechanical clamping fixture	Wear	Smaller readings due to loose fixtures
3.5	L—shaped handle	Permanent Deformation	Inaccurate exertion of torsion, no effect on measurement
3.6	Air pressure valve	Air leak	Insufficient air pressure provided



Table 4: FMEA Part 2

	Severity (S)	Potential Causes and Mechanisms of Failure	Occurrence (O)	Current Design Controls Test	Detection (D)	RPN	Recommended Action
1	7	Open/short circuiting, processing error, etc.	4	Test runs on the entire device	1	28	Design a case to protect the circuits
1.5	7	Too much external force, exposed to high temperature, etc.	4	Resistance measurement	1	28	Cover strain gauges to prevent users from touching
3.1	3	Too much tension/compression	1	Drastic plastic deformations can be visible	6	18	Set maximum weight regulation on instructions, design standard weights for normal use
3.2	5	Too much bending force	1	Drastic plastic deformations can be visible	5	25	Set maximum weight regulation on instructions, design standard weights for normal use
3.2	7	Too much torsion	1	Drastic plastic deformations can be visible	5	35	Set maximum weight regulation on instructions, design standard weights for normal use
3.3	8	External influence	4	Drastic plastic deformations can be visible	1	32	Set the upper limit of the maximum air pressure that can be charged
3.1-3.3	6	Long time usage, poor metal quality	5	Supersonic detection	2	60	Set maximum running cycles on instructions, suggest regular replacements of metal parts
3.4	3	Frequent friction with load cell	6	Probably visible	3	54	Add lubricating oil to the fastening part
3.5	2	Hanging for long time or overweight	4	Spirit level measurement	1	8	Reduce the hanging time and weight of objects
3.6	8	Lax sealing	2	Drastic plastic deformations can be visible	2	32	Replace the air valve



## **4.1 Critical Failures**

The failure mode with the highest risk priority is fatigue on metal components on the load cell, whatever the load type is. Although it is very unlikely to occur on brand new products, the risk becomes higher with time and usage. Also, because most fatigue failures begin with interior voids, metals purchased with poor quality would speed up this process. Considering the inevitability of this failure mode and the inconvenience for user detection, it is suggested that users could replace the load cell when it reaches designed maximum running cycles.

The wear on the mechanical clamping fixture ranks second overall in risk priority. Similar to fatigue, this failure mode would only take effect in the long term. Although a loose fixture would not cause a complete failure on the entire device, it would gradually reduce its measurement accuracy in a relatively invisible manner. Luckily, the solution to it is not that costly: adding lubricating oil and reducing the times of unfastening the load cell are effective ways to minimize the friction effect.

The following failure modes with high priority scores are yielding on load cells for axial, bending, and torsional strain. If the metal piece yields, its mechanism for deformation would change and therefore making the feedback from strain gauges meaningless. However, the chance of yielding among the three components are not quite the same. The metal hollow bar for torsional strain measurement has the highest risk, which could easily yield under a few degrees of twisting. In contrast, axial forces need to be large enough to reach the same effect. After all, whatever the cause is, these failure modes could be prevented by appropriate instructions. As long as users don't exceed the force limits upon using the device, there shouldn't be any issues in this aspect.

## **4.2 Risks and Trade-offs Analysis**

There may be some conflicts in the improvement of certain risks. For example, if we want to protect the strain gauge, we can cover it with a protective film. But in this case, it is necessary to consider whether the protective film will hinder the strain of the strain gauge. In order to ensure that the furniture will not wear out, we consider adding lubricating oil, but this may cause the clamp to not be tight, and the error of the data will become larger. In order to protect the circuit, this team decided to design a box to install the entire circuit, but this will make the circuit inside the box too complicated, and it will be more difficult to troubleshoot when a fault occurs. In order to prevent each metal rod from breaking, we can set the maximum number of cycles for testing, but these tests require high technicality and must have professional instruments, which will greatly increase our costs.



## 5 Design Selected - First Semester

### 5.1 Design Description

The team's final design, the "Puzzle" (Figure 3). The four parts can be disassembled and assembled like a puzzle. The overall volume will be much smaller. Moreover, we only use one Arduino to link at the end, which reduces the cost. At the same time, we choose to use batteries for power supply and a single capacitive screen, so that the entire device will be more complete and independent. Although this may seem ordinary, it is very practical. The only flaw is the battery life and the stability of the power supply.

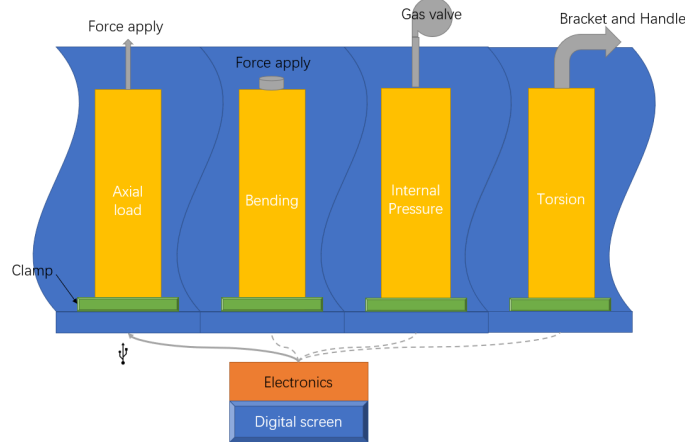

Figure 3: Design Concept - "Puzzle"

### 5.2 Rationale for Design Selection

In this part, our team will use detailed data and equations to show that our design is reliable.

#### 5.2.1 Axial Load

$$\epsilon_x = \frac{F}{AE} \quad \epsilon_y = -\nu \frac{F}{AE}$$

Equation 1: Strain on x and y axis

Table 5: Axial Load Strain Calculations

Quantity	Definition	Value (Unit)
$F$	Applied force	100 N
$A$	Object cross-sectional area	$0.00000375 \text{ m}^2$
$E$	Young's modulus	73.1 Gpa
$\nu$	Poisson's ratio	0.33



$\epsilon_x$	Strain in x direction	364.8 microstrain
$\epsilon_y$	Strain in y direction	-120.4 microstrain

### 5.2.2 Bending

$$\sigma_x = \frac{M_z y}{I_z} \quad \sigma = \epsilon \cdot E$$

Equation. 2 Bending Moment and Strain

Table 6: Bending Strain Calculation

Quantity	Definition	Value (Unit)
F	Applied force	100N
E	Young's modulus	73.1Gpa
$\sigma_x$	Bending Stress	265.9370725 Microstrain
$M_z$	Moment about the axis	45 N
y	Distance to the neutral axis	0.45 m
$I_z$	The second moment of area	0.00000104166667 m <sup>3</sup>

### 5.2.3 Torsion

$$\frac{T}{J} = \frac{G \times \theta}{L}$$

Equation 3: Torque and Stress

$$I_z = \frac{\pi(D^4 - d^4)}{32}$$

Equation 4: Polar Moment of Inertia

Table 7: Torsion Strain Calculation

Quantity	Definition	Value (Unit)
T	Torque or twisting moment	49.05 N/m
D	Density	2.78 g/cm <sup>3</sup>



G	Modulus of rigidity (PanGlobal and Reed's) or shear modulus	26900 Mpa
L	Length of the shaft	0.6 m
D1	Outer Diameter	0.1 m
D2	Inner Diameter	0.098 m

Through the above formula and equation, we can get the size of the rotation angle as 0.8224718592 degrees.

### 5.2.4 Internal Pressure

According to customer requirements, the force we apply is about 10bar air pressure. According to the following formula, we can calculate the strain.

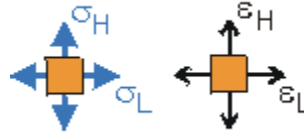

$$\epsilon_H = \frac{\sigma_H}{E} - \nu \frac{\sigma_L}{E} = \frac{pR}{Et} \left(1 - \frac{\nu}{2}\right)$$

Equation.5: Strain in Vertical Direction

$$\epsilon_L = \frac{\sigma_L}{E} - \nu \frac{\sigma_H}{E} = \frac{pR}{Et} \left(\frac{1}{2} - \nu\right)$$

Equation.6: Strain in Horizontal Direction

Table 8: Internal Pressure Parameters

Quantity	Definition	Value (Unit)
p	Pressure	1000000 (N/m <sup>2</sup> )
R	Outer Diameter	0.1 (m)
E	Young's modulus	73.1 (Gpa)
t	Width	0.001 (m)
ν	Poisson's ratio	0.3333

So we can get the result.  $\epsilon_H = 569.99544$ ,  $\epsilon_L = 113.999088$ . This shows that this design is feasible.

## 5.3 Implementation Plan

### 5.3.1 Fabricate prototype and proof-of-concept creation

#### 5.3.1.1 Overview

As part of the demonstration of the project, the team built a prototype at the end of first semester. In





general, the building of the prototype follows the schematic diagram (Figure 4) of a strain measurement device, which turned out to be a preliminary system including strain gauges, a complete circuit, and computer output through programs. Based on that, the team also conducted some simulation tests on the prototype, where a shot of the entire system (Figure 5) was taken at the scene.

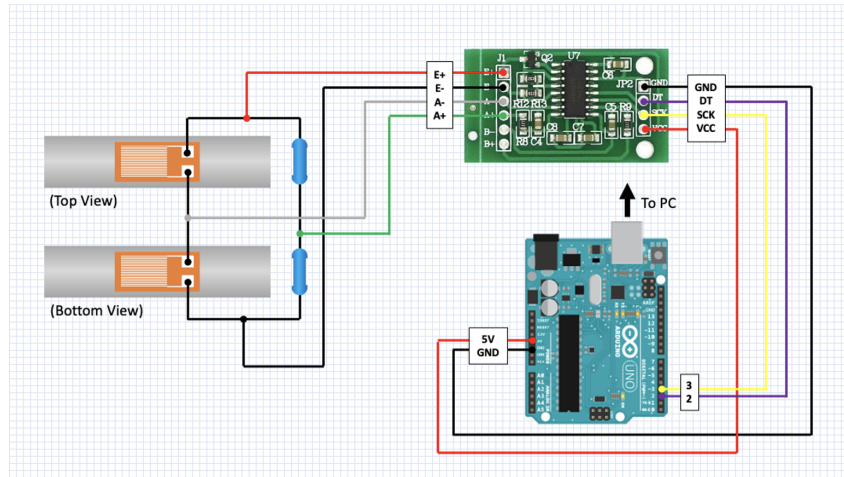

Figure 4: Schematic Diagram of Strain Measurement Device

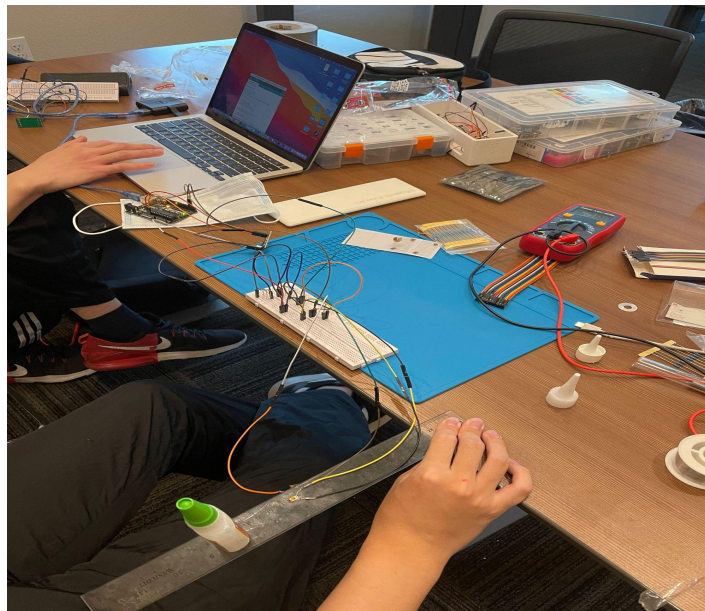

Figure 5: Overview of the Prototype



### 5.3.1.2 Limitations

Due to the stage of the project, there are some limitations with the prototype. First, instead of testing strain under all four load types, the team only put bending in trial. This was because the team was unable to find a metal piece with appropriate dimensions, meaning the part needs to be replaced without affecting too much on the measurement. For bending, a plastic ruler could be a decent replacement of the metal bar, especially for its susceptibility to deform, which could generate a wider range of results.

Also, because of the limited time, the team was only able to construct one configuration of strain gauges, which is a half bridge with both strain gauges sharing one route in the circuit. The configuration could coordinate with bending strain measurements.

### 5.3.1.3 Prototype Decomposition & Testing Procedure

The figure below (Figure 6) shows the strain gauges on the plastic ruler, which were roughly glued to the midpoint of the ruler on both sides. An object (around 10 grams) was placed on the further end of the ruler. By changing the position of the object, the team was able to get different strain readings from the prototype.

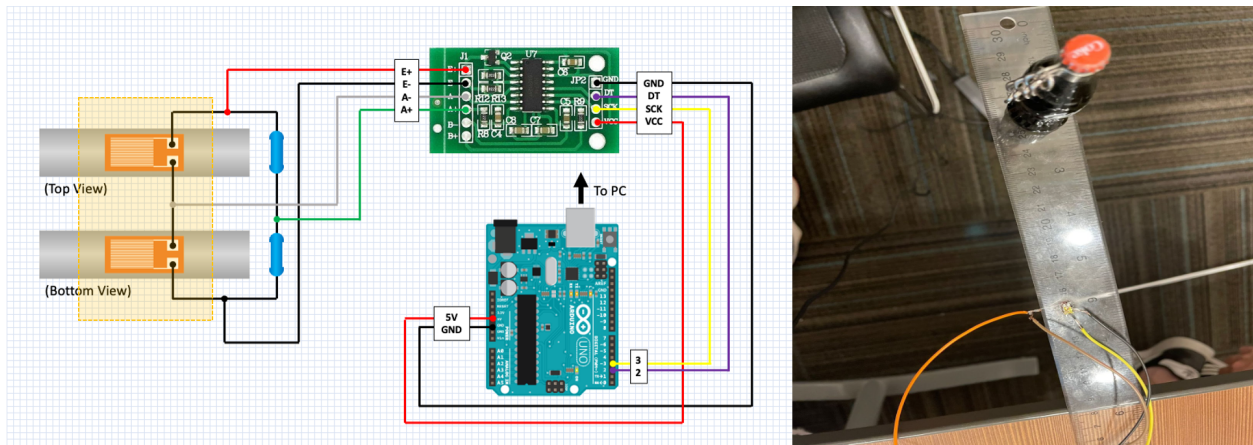

Figure 6: Strain Gauges on Ruler



The next figure (Figure 7) shows the resistors in the half bridge circuit. This part of the circuit was connected on a breadboard. In order to match the resistance of strain gauges (around 350 ohms), each set of resistors were composed of three resistors in series, including one 330-ohm resistor and two 10-ohm resistors. In the future, they will be likely to be replaced by potentiometers for higher accuracy.

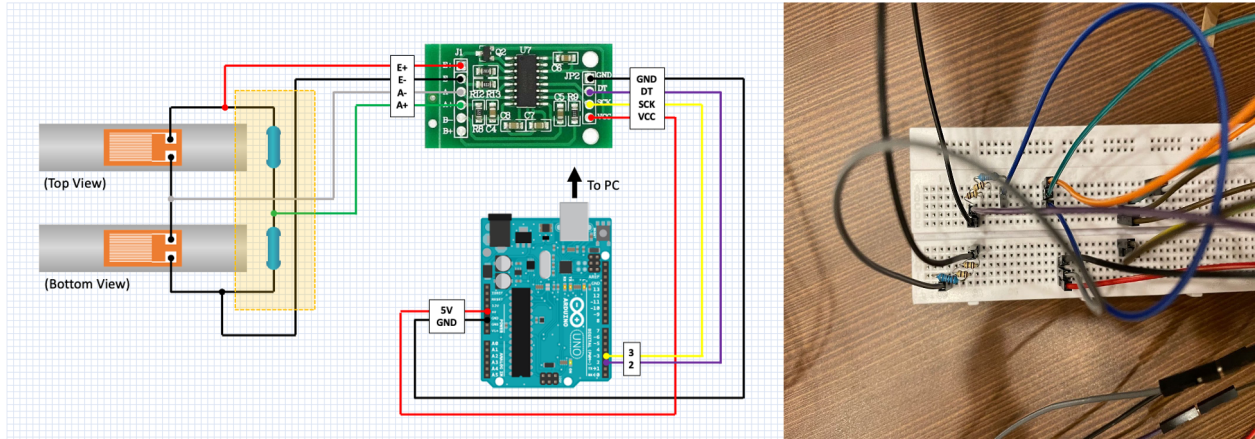

Figure 7: Connection between HX711 and Half Bridge Circuit

Below (Figure 8) shows how HX711 is connected with other parts. In the photo on the right hand side, the lower part of HX711 is connected to four pins on the Wheatstone bridge: power (E+), ground (E-), and signal (A+ and A-), which the selection of channel A means HX711 will generate a voltage gain of 128. The upper part of HX711 is connected to the Arduino board, with also four pins involved: power (5V), ground (GND), and digital pins 2 and 3.

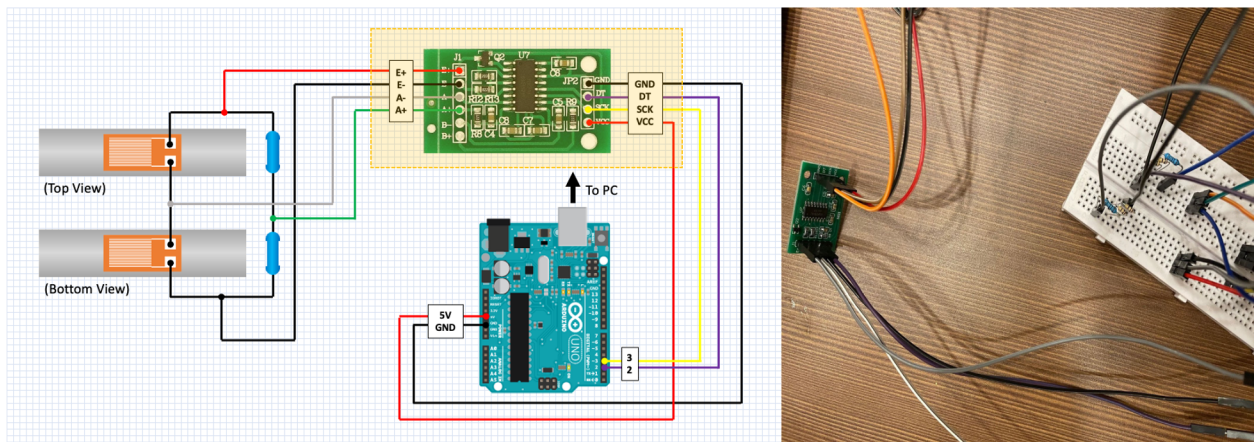

Figure 8: Connection between HX711 and Wheatstone Bridge





The following figure (Figure 9) shows the Arduino board and how it is connected. The interface on its left is connected to a computer through a USB port, and data is displayed on the computer through two programs. The first one was programmed on Arduino, which sends clock signals to HX711 and transforms its feedback (in the form of voltage levels) to a digital reading. The reading can be converted to a voltage difference between two signal pins on the Wheatstone bridge, and therefore be turned to a strain value with the help of some additional mathematical equations. The second program was written on Processing, which is more of an application designed for artists, was used for some graphics design and the final display of the above results.

The codes for both programs can be seen in the Appendix A and Appendix B..

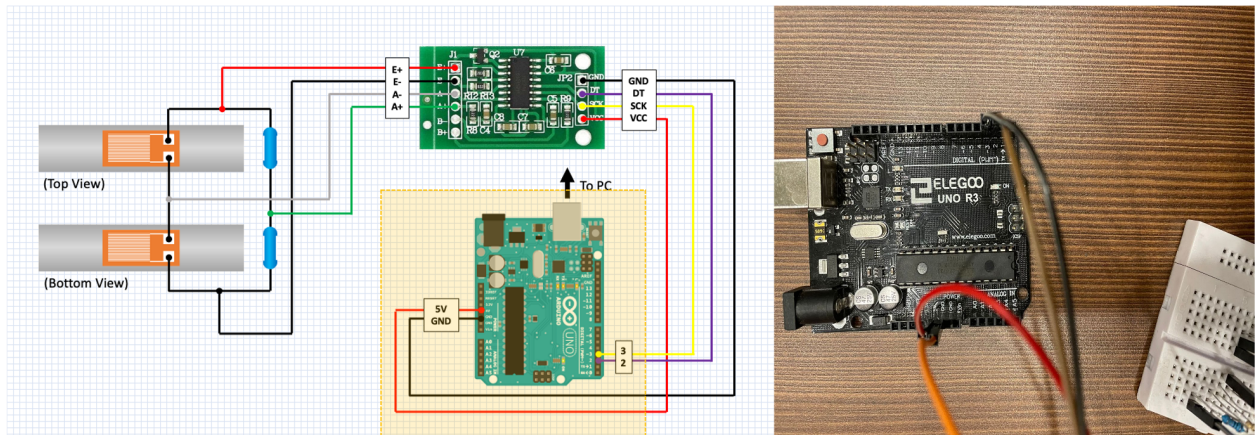

Figure 9: Arduino Board and Its Connections

### 5.3.1.4 Result & Conclusion

After the team applied the force on the plastic ruler, the strain gauge changed while making the resistance of the gauge changed. That change will be captured and enlarged by the HX711. The data can be displayed on the computer after processing by Arduino. You can see the final reading for the computer screen in the figure.

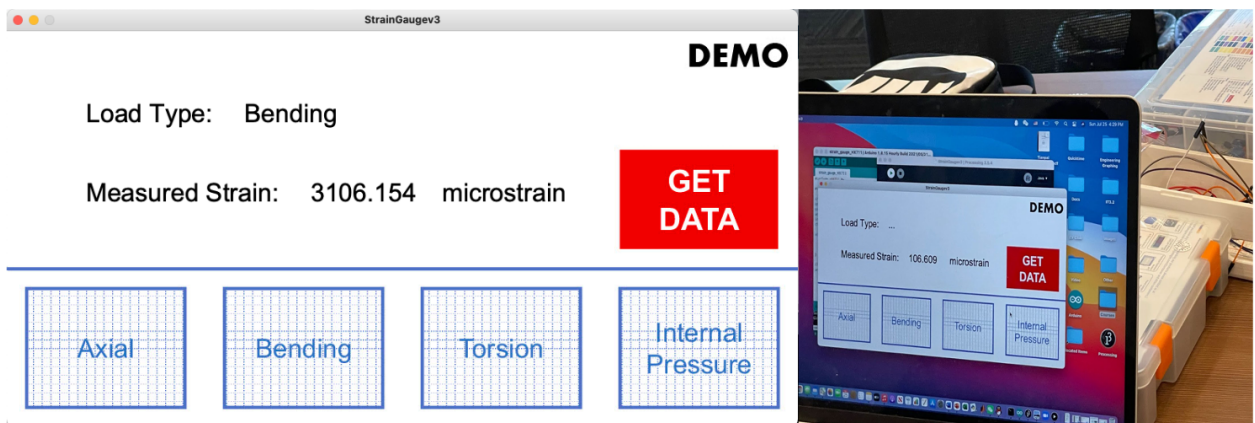

Figure 10: Program Interface & A Shot of Computer Reading



### 5.3.2 Bill of materials

This Bill of Materials form is an important part of our strain gauge project (Appendix C). The price required for this item list is completely within the control range. In general, the list is divided into three parts. They are Electronics, load cell, and tools parts. The Electronics part consists of two aspects: data acquisition and data processing. The data acquisition is mainly the Wheatstone bridge connected by the strain gauges. The bridge includes a breadboard, variable resistors and wires. In the data processing part, Arduino and HX711 are the most important. They are responsible for the amplification and conversion of the bridge signal. Finally, it is displayed on the capacitive touch screen. The load cell part is mainly composed of a base and a measuring metal block. They are connected and fixed by clamps. For different kinds of force methods, our team uses different methods, such as using air valves, pulleys and handles. The tool part mainly includes glue, screws and solder, which are mainly responsible for the installation of the load cell and the fixing of the strain gauge.

## 5.4 Subsystem Concepts with CAD models

This section mainly explains the team's five subsystems (mainly about circuit connection and data processing) and their corresponding designs.

### 5.4.1 Subsystem #1: Load Cell

The Load cell subsystem includes four different measurements, axial force, bending, torsion and internal pressure (Figure 11). The measurement metal is deformed by applying force in different ways. For the axial force, a pulley is used to convert the vertical pull of the weight into a horizontal pull. For bending, apply vertical gravity at the end points. For torsion, place a handle at the end and use a bracket to counteract gravity. Finally, measure the internal pressure and use an air pump to pump air to the air valve at the end of the hollow metal column.

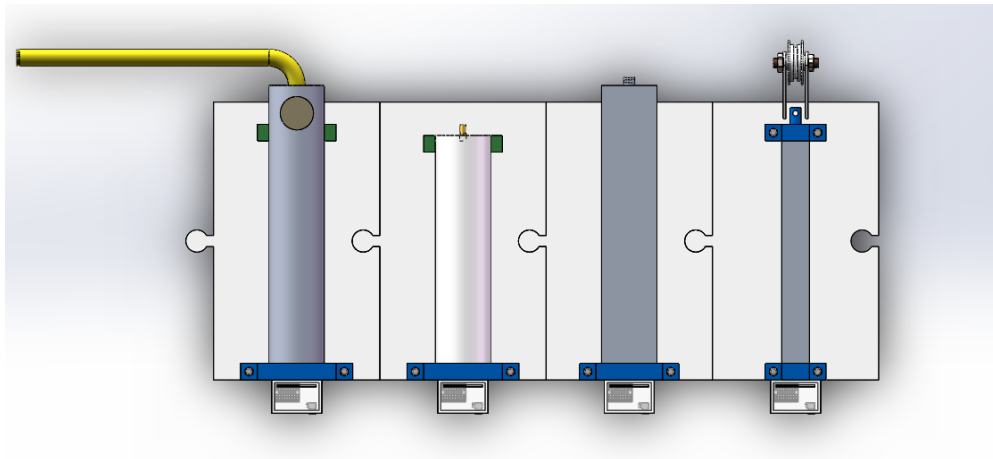

Figure 11: Load Cell Part

### 5.4.2 Subsystem #2: Data Acquisition

The data acquisition subsystem of the device includes the strain gauge and the Wheatstone bridge circuit (Figure 12). Technically, there is no difference among all design concepts in this subsystem as they share the same circuit layout. The only thing that matters is the selection among quarter bridge, half bridge, and full bridge, depending on the amount strain gauges and resistors in a Wheatstone bridge. The team would prefer full bridges for its high sensitivity and low temperature effects. However, such selection is still



independent from design concepts. In terms of the cad model (Figure 13), our team designed a box to accommodate the electric bridge. The strain gauge can be connected to the breadboard[2] through the gap in the lid after connecting the metal rod.

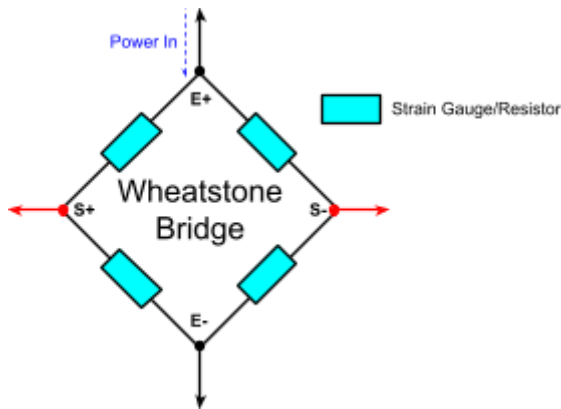

Figure 12: Wheatstone Bridge Circuit

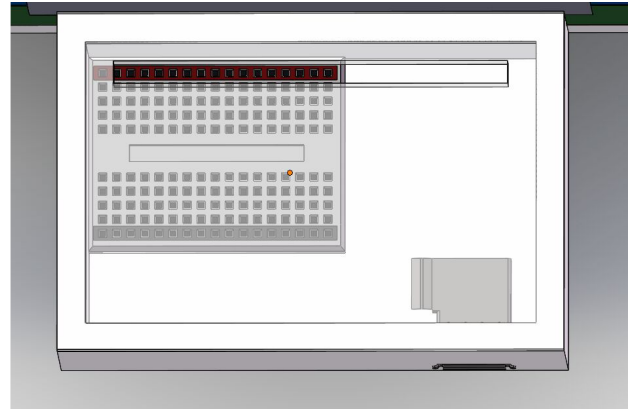

Figure 13: Bridge circuit box

### 5.4.3 Subsystem #3: Data Processing

This subsystem includes the HX711 load cell amplifier and the Arduino board, with the former performing signal conversions and the latter receiving the outputs. Due to both components being existing products and the circuit connections fixed, there is no room for design variables between them. However, their connections with the subsystem of data acquisition can have more than one approach. In fact, the circuit between them is not supposed to be always closed. Designing a “port” between them will increase the flexibility of the device and reduce electronic components (by sharing the data processing section). Based on that idea, two concepts were designed to make it possible.

This concept works similarly with the previous one, only replacing USB extension wires by terminal blocks (Figure 14). As a comparison, it has an advantage in terms of technical difficulty, as jumper wires can be directly inserted into the terminal block without soldering. However, they will not be as effective as USB ports. Considering the pros and cons between these two concepts, the team still decides to select USB extension wires for their better fit on a product.

In the CAD model, our team designed a trapezoidal box (Figure 15). Arduino[3] and HX711 are placed in the box and connected to the usb interface[4]. A capacitive touch screen[5] can be placed on the slope of the box, which is more convenient than connecting to a computer. It will be mentioned in the next subsystem

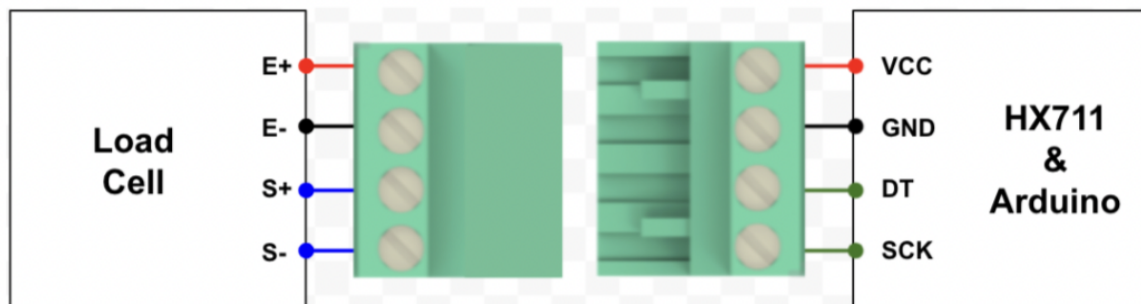

Figure 14: Data Processing - Connection with Terminal Blocks

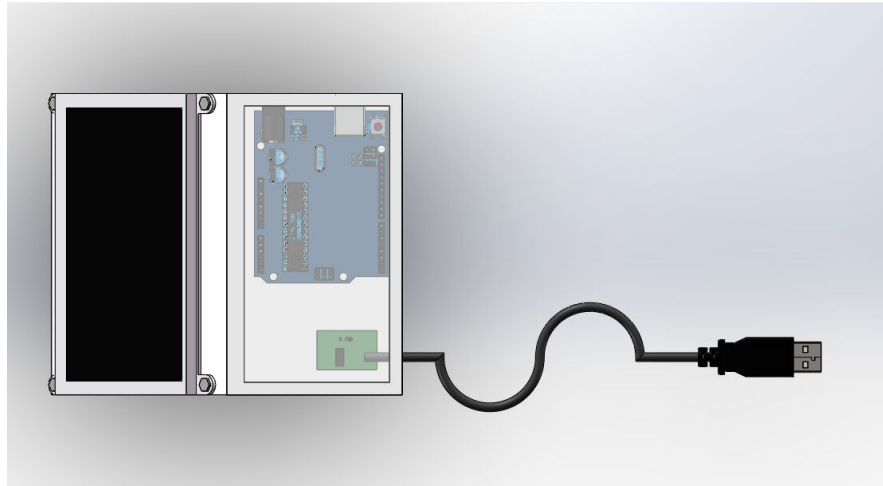

Figure 15: Box of electronics

#### 5.4.4 Subsystem #4: Serial Communication

This section mainly focuses on the Arduino program and a screen. Since the screen hasn't been set up in the team's existing system, the job is currently accomplished by Processing, a programming application which could display graphics. As long as the environment of this subsystem is completely virtual, there is no need to generate design concepts in this part.

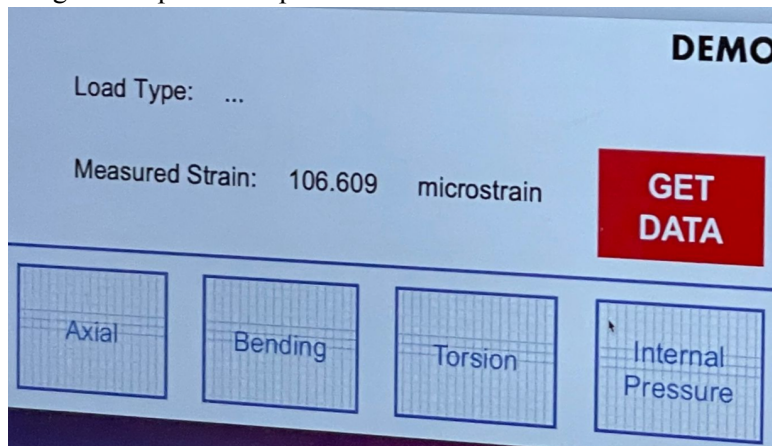

Figure 16: Display screen generated by programming

#### 5.4.5 Subsystem #5: Assembly

In order to maintain the shape of the turntable, this design solution requires four measuring devices to be fixed around a central point.

### 5.5 Gantt chart

As it is shown in Appendix D, after completing the final report for this semester, the team also planned the second part of the capstone for the next semester. Firstly the team will do the Team Post Mortem Analysis of ME 476C, which will be used to review the work the team have done in the past summer semester and find the areas for improvement. Then the team will do the self-learning and hardware summary. After finishing the following peer evaluation, the team will check the website and write the midpoint report. The Individual Analysis and device summary will be finished before Halloween. After



the holiday, the team will do the drafts of posters and testing proof. The last parts are Final Poster and Operation Manual, Final Report and CAD package. At the end of Fall semester. The team will do the final presentation and the final peer evaluation. If all goes well, the team will complete the capstone on time.





## 6 Conclusion

The goal of this project is to build a laboratory strain measurement device. It can measure four different types of strain -- Axial load, bending, torsion and internal pressure. Based on the requirements of the client, its size must be suitable for the laboratory and the total cost can not exceed 1500\$. Also, the accuracy is important, all the strain should be controlled around a few hundreds microstrain.

So this semester the team completed the theoretical design perfectly as expected and designed this device called "Puzzle". In this report, the team introduced in detail how our design meets various requirements, and carried out detailed risk estimation and analysis, scoring and giving solutions to each potential risk, which will provide great help to the work of the next semester. At the same time, the team developed a clear test plan for the entire device, covering every key requirement, including circuit, size, accuracy, and cost. Each test has a specific method and test time and location to ensure completion. In addition, according to the course schedule for the next semester, the team designed a detailed Gantt chart to subdivide the task into each time period to ensure that the task can be completed on time and efficiently.

In general, the team completed the required tasks perfectly this semester. The team members helped each other and overcame many difficulties together. Not only that, we also designed an additional semi-finished product for measuring bending. Although its appearance is rough and the data may not be accurate, it does prove that our design is completely feasible. It can be believed that according to this idea, the team will be able to complete the invention of the final product next semester.



## 7 REFERENCES

- [1] David.Trevas, “Strain Ga(u)ge Demonstration Apparatus”, Project Descriptions, NAU ME Department, [Accessed:20-Jun-2021]
- [2]“Free CAD Designs, files & 3D models: THE GrabCAD community library,” Free CAD Designs, Files & 3D Models | The GrabCAD Community Library. [Online]. Available: <https://grabcad.com/library/35mmx45mmx8mm-breadboard-17x10-holes-1>. [Accessed: 03-Aug-2021].
- [3]“Free CAD Designs, files & 3D models: THE GrabCAD community library,” Free CAD Designs, Files & 3D Models | The GrabCAD Community Library. [Online]. Available: <https://grabcad.com/library/arduino-uno-r3-montaj-from-ziya-can-tatar-1>. [Accessed: 03-Aug-2021].
- [4]“Free CAD Designs, files & 3D models: THE GrabCAD community library,” Free CAD Designs, Files & 3D Models | The GrabCAD Community Library. [Online]. Available: <https://grabcad.com/library/usb-plug-6>. [Accessed: 03-Aug-2021].
- [5]“Free CAD Designs, files & 3D models: THE GrabCAD community library,” Free CAD Designs, Files & 3D Models | The GrabCAD Community Library. [Online]. Available: <https://grabcad.com/library/5-inch-touch-screen-1>. [Accessed: 03-Aug-2021].



## 8 APPENDICES

### 8.1 APPENDIX A: Arduino Codes

```
#include <HX711.h>

#include "HX711.h"

// HX711 circuit wiring
const int DT_Pin = 2;
const int SCK_Pin = 3;

void setup() {
  Serial.begin(57600);
}

// Function for reading the digital signal
unsigned long ReadCount(void) {
  unsigned long Count;
  unsigned char i;

  // Clock set to LOW
  // Record the digital signal using "Count"
  digitalWrite(SCK_Pin, 0);
  Count = 0;

  // Generate clock signal until DT becomes LOW
  while (digitalRead(DT_Pin) == HIGH);

  // Read the digital signal every once in a clock cycle
  // with most-significant bit first (MSBFIRST) in order
  // Repeat the clock 24 times
  for (i = 0; i < 24; i++) {
    digitalWrite(SCK_Pin, HIGH);
    delayMicroseconds(1);
    Count = Count << 1;
    digitalWrite(SCK_Pin, LOW);
    delayMicroseconds(1);

    // Return the bit based on the state of DT
    if (digitalRead(DT_Pin) == HIGH) {
      Count | 1;
    }
  }

  // Perform an additional clock cycle
  // for a gain of 128 in channel A
  digitalWrite(SCK_Pin, HIGH);
  delayMicroseconds(1);
  Count = Count ^ 0x800000; // Convert to decimal number
  digitalWrite(SCK_Pin, LOW);
  delayMicroseconds(1);
  return(Count);
}
```



```
void loop() {  
    // Print the result on serial monitor  
    Serial.print("HX711 reading: ");  
    Serial.println(ReadCount());  
}
```



## 8.2 APPENDIX B: Processing Codes

```
import processing.serial.*;

// Screen
PImage bgImg;
PFont font;
String line1 = "Load Type: ";
String loadType = "...";
String line2 = "Measured Strain: ";
boolean inited = false;
boolean clicked = false;
int[][] buttons = {{25, 325, 200, 150},
                  {275, 325, 200, 150},
                  {525, 325, 200, 150},
                  {775, 325, 200, 150},
                  {775, 150, 200, 125}};

// Serial communication
Serial myPort; // Create object from Serial class
int portIndex = 2; // set this to the port connected to Arduino
int lowByte = 0;
int midByte = 0;
int highByte = 0;
float reading;
float voltage;
float GF = 2.1;
float strain;
int pos = 0;

void setup() {
  // Screen
  size(1000, 500);
  frameRate(20);
  bgImg = loadImage("StrainGaugeGraphicsDemo.jpg");

  // Serial communication
  println(Serial.list()); // print the list of all the ports
  println(" Connecting to -> " + Serial.list()[portIndex]);
  myPort = new Serial(this, Serial.list()[portIndex], 57600);
}

int selectButton() {
  int i;
  for (i = 0; i < 5; i++) {
    if (mouseX >= buttons[i][0] && mouseX <= buttons[i][0] + buttons[i][2]) {
      if (mouseY >= buttons[i][1] && mouseY <= buttons[i][1] + buttons[i][3]) {
        return i;
      }
    }
  }
  return -1;
}
```



```
void serialEvent(Serial myPort) {
  if (myPort.available() == 1) {
    if (pos == 0) {
      lowByte = myPort.read(); // Read low 8 bits
      pos++;
    } else if (pos == 1) {
      midByte = myPort.read(); // Read middle 8 bits
      pos++;
    } else if (pos == 2) {
      highByte = myPort.read(); // Read high 8 bits
      reading = lowByte + pow(16, 2) * midByte + pow(16, 4) * highByte; // Sum up HX711 reading
      voltage = reading * 20 / 8388608;
      strain = getStrain(loadType);
      pos++;
    } else {
      myPort.read(); // Read invalid data but without displaying
    }
  }
}

float getStrain(String loadType) {
  //switch (loadType) {
  //case "Bending": {
  //  strain = 2 * voltage / GF;
  //}
  //case "...": {
  //  //strain = 0;
  //}
  //}
  return strain * 1000;
}

void pressButton() {
  int buttonID = selectButton();
  switch (buttonID) {
    case 0:
      loadType = "Axial";
      break;
    case 1:
      loadType = "Bending";
      break;
    case 2:
      loadType = "Torsion";
      break;
    case 3:
      loadType = "Internal Pressure";
      break;
    case 4:
      myPort.write('1'); // Write a signal to serial port
      pos = 0;
      serialEvent(myPort);
      break;
    case -1:
      loadType = "...";
      break;
  }
}
```



```
void printText() {
  fill(255);
  noStroke();
  rect(100, 84, 650, 150);

  fill(0);
  textAlign(LEFT, CENTER);
  text(line1, 100, 100);
  text(loadType, 300, 100);
  text(line2, 100, 200);
  text(strain, 375, 200);
  text("microstrain", 550, 200);
}

void draw() {
  if (inited == false) {
    image(bgImg, 0, 0, 1000, 500);
    font = createFont("Arial", 32);
    textFont(font);
    inited = true;
  }
  pressButton();
  if (mousePressed) {
    printText();
  }
}
```



### 8.3 Appendix C: Bill of materials

Bill of Materials									
Team									
Part #	Part Name	Qty	Description	Functions	Material	Dimensions	Cost per Unit	Total Cost	Link to Cost estimate
1.1	Arduino R3 board	1	Microcontroller board	Receive and read digital signals	Existing product		\$12.00	\$12.00	<a href="https://www.amazon.com">Amazon.com</a>
1.2	Touch screen	1	Capacitive	Display measurements	Existing product		\$50.00	\$50.00	<a href="https://www.amazon.com">Amazon.com</a>
1.3	HX711 Load Cell Amplifier	8	ADC	Convert analog signals to digital, amplify voltage	Existing product		\$2.00	\$16.00	<a href="https://www.amazon.com">Amazon.com</a>
1.4	Dupont line 120pcs	1	Conduct electrical signals	Connect circuits	Existing product		\$7.00	\$7.00	<a href="https://www.amazon.com">Amazon.com</a>
1.5	Strain Gages—Linear Pattern	8	Sensor whose resistance varies with applied force	Measure strain by resistance change	Existing product	350 ohms	\$12.00	\$96.00	<a href="https://shopvpg.crm.mobiledesk.com">Shopvpg.crm.mobiledesk.com</a>
1.6	Strain Gages—Planar Rosette	2	Sensor whose resistance varies with applied force	Measure strain by resistance change	Existing product		\$75.00	\$150.00	<a href="https://shopvpg.crm.mobiledesk.com">Shopvpg.crm.mobiledesk.com</a>
1.7	Resistors	6	Variable	Complete	Existing	100 to	\$12.	\$72.0	<a href="https://www.amazon.com">Amazon.com</a>





	100pcs		resistance	Wheatstone bridges	Engineering product	500K ohms	00	0	
1.8	Breadboard	4	A thin plastic board used to hold electronic components	Connect circuits	Plastic and metal		\$3.00	\$12.00	<a href="https://www.amazon.com">Amazon.com</a>
1.9	USB Extension Cable—Male to Female	4	There is a USB interface wire at one end	Connect mechanical and electronic sections	Plastic and metal		\$10.00	\$40.00	<a href="https://www.amazon.com">Amazon.com</a>
2.1	Cyanoacrylate Adhesive Super Glue	1	Adhesive liquid	Paste strain gauges on metals	Cyanoacrylate		\$12.00	\$12.00	<a href="https://www.amazon.com">Amazon.com</a>
2.2	Soldering Iron Kit	1		Soldering	Existing product		\$20.00	\$20.00	<a href="https://www.amazon.com">Amazon.com</a>
2.3	Screwdriver set	1	Tools for turning screws with slotted heads	Assemble product	Existing product		\$24.00	\$24.00	<a href="https://www.amazon.com">Amazon.com</a>
2.4	Insulation tape	1	Tools that can weld electronic components		Rubber		\$20.00	\$20.00	<a href="https://www.amazon.com">Amazon.com</a>
2.5	Nuts and Bolts 100pcs	1	Tools for assembling and fixing parts	Assemble product	Metal		\$20.00	\$20.00	<a href="https://www.amazon.com">Amazon.com</a>



3.1	Metal shim	1	Fixed size metal parts	Build load cells	Aluminum alloy		\$30.00	\$30.00	<a href="http://Mcmaster.com">Mcmaster.com</a>
3.2	Metal bar	1	Fixed size metal parts	Build load cells	Aluminum alloy		\$30.00	\$30.00	<a href="http://Mcmaster.com">Mcmaster.com</a>
3.3	Metal hollow bar	2	A hollow bar that filled with air	To contain air so that measure the internal pressure	Aluminum alloy	Length /Width : 0.6/0.4 m Outer diameter: 0.2 m Inner diameter: 0.196 m	\$30.00	\$60.00	<a href="http://Mcmaster.com">Mcmaster.com</a>
3.4	Mechanical clamping fixture	4	Items to fix bar	Fix load cells	stainless steel		\$20.00	\$80.00	<a href="http://Amazon.com">Amazon.com</a>
3.5	L-shaped handle	1	L-shaped metal handle	Apply torsion	Aluminum alloy	Length : 0.5m Diameter: 0.098 m	\$10.00	\$10.00	<a href="http://Amazon.com">Amazon.com</a>
3.6	Air pressure valve	1	Brass Schrader Valve	Air channel	Brass	1.45 x 0.43 x 0.5 inches	\$2.50	\$2.50	<a href="http://Amazon.com">Amazon.com</a>
3.7	Inflator pump	1	Bike pump with pressure gauge	Provide 10 bar pressure	Existing product	24 x 9.5 x 5 inches	\$39.00	\$39.00	<a href="http://Amazon.com">Amazon.com</a>
3.8	3D printing base	4		Build product casing	PVC		\$40.00	\$160.00	<a href="http://Nau.edu/library/3d-printing/">Nau.edu/library/3d-printing/</a>



<b>Total Cost Estimate:</b>	\$962. 50
-----------------------------	--------------

### 8.4 Appendix D: Gantt chart





		22-29		October 29-31	November 1-5
Device summary		Peer Eval 2		Drafts of poster	
Collection device parts	Assembly Device	Check reinforcement device		Take product photos	Write promotional content
				Make a logo	

		November				
Date	5-12					
Task	Testing Proof					
Section	Check Torsion	Check Internal Pressure	Check Bending	Check Axial loading	Check code	Retouch Final poster
Ziyu Wei						
Zhicheng Jiang						
Tianpai Le						
Yifan Chen						
Rui Xu						

		12-19	19-25	25-28	28-29	29-30
Final Poster and Operation Manual		Prepare Final Presentaion		Thanksgiving Day	Final Presentation	Final Report and CAD package
Write operation manual	Check for grammatical errors and corrections					Customer and Engineering Requirements
						Introduction

		December				6-13(Final Week)	
Date	1-6						
Task	Final Report and CAD package				Website	Peer Eval 3	
Section	Standards, Codes, and Regulations	Testing Procedures	Desgin exhibit	CAD package	Reference	Add content to the website	Check the website
Ziyu Wei							
Zhicheng Jiang							
Tianpai Le							
Yifan Chen							
Rui Xu							

